

# Toilets

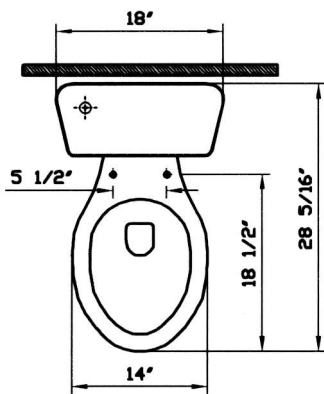

Description	: Atlantis Elongated Front Bowl
Code Nr	: 5051-XXX-0075
Compatible items	: 6853-XXX-5004 Tank with white plated trim lever on the left hand side 6853-XXX-5008 Tank with white plated trim lever on the left hand side (lined) 6853-XXX-5005 Tank with chrome plated trim lever on the left hand side 6853-XXX-5009 Tank with chrome plated trim lever on the left hand side (lined) 422885 Toilet Seat (elongated)
Water use	: 1.6 GPF
Water surface	: 9 1/4" x 8 1/16"
Water depth from rim	: 6 1/2"
Rough-in	: 12"
Minimum water pressure	: 20 psi.
Trap diameter	: 2"
Trap seal depth	: 2 1/8"
Shipping weight	: 5051 : 43 lbs. 6853 : 34 lbs.
Shipping dimensions	: 5051 : 15 3/16"W x 29 1/8"L x 18 11/16"H 6853 : 8 1/4"W x 19 5/16"L x 16 9/16"H
Installation guides	: 312851
Fixings	: Bolt cap (310359/310306)
Material	: Vitreous china
Colors	: 003 White 068 Biscuit, 070 Black (Special Colors) "XXX" indicates the color
Standards	: ASME A112.19.2M, ASME A112.19.6, CSA B45
Warranty	: 10 year limited warranty

1



2

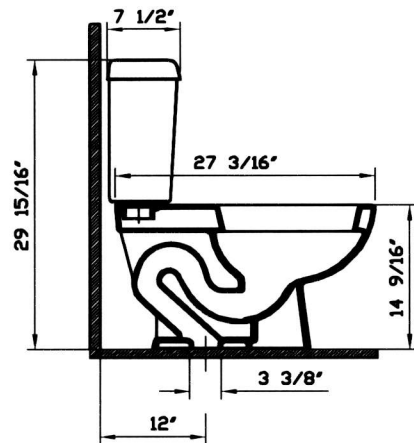

3

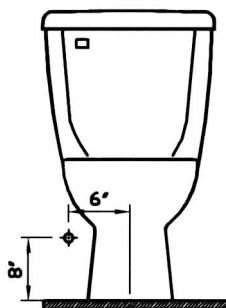

Notes:

- DIMENSIONS SHOWN FOR LOCATION OF SUPPLY IS SUGGESTED.
  - INSTALLATION INSTRUCTIONS SUPPLIED WITH TOILET.
  - TANK FITTING, CHROME PLATED METAL TRIP LEVER AND 2 BOLT CAPS INCLUDED.
  - PROVIDE SUITABLE REINFORCEMENT FOR ALL WALL SUPPORTS.
- IMPORTANT: Dimensions of fixtures are nominal and may vary within the range of tolerances established by ASME Standards A112.19.2M, A112.19.6 and CSA Standard B45. These measurements are subject to change or cancellation. No responsibility is assumed for use of superseded or voided pages.