



CHECKLIST FOR COMPLETING AN APPLICATION TO INSTALL UNDERGROUND WATER / FIRE SERVICE

Drawings must be prepared on City-provided, standard border and title block sheets, or good quality mylar. Each drawing must be stamped, signed and dated by either a registered civil engineer or licensed C-16 contractor.

Drawings must be accompanied by an engineer's estimate for the complete underground fire service from City's main to building, which will be used to determine the amount of each bond and the amount of cash deposit for plan checking and inspection. (See the Permit Application, and instructions thereto.)

Submit an initial cash deposit of \$500.00. (Additional deposits will be required to cover the costs of plan review and inspection as part of the permit process.)

The initial submittal shall consist of three(3) sets of blueprints for plan review.

After plans are considered complete, fill out the "Permit Application", and submit bonds and insurance, as noted on the instruction for completing the permit.

I. The following "general items" must be shown on the drawings:

- _____ A. Vicinity map, north arrow, scale, bench mark
- _____ B. The property lines and structure to be served
- _____ C. Easements or public right-of-way across or adjacent to the subject property.
- _____ D. The new underground service line with appurtenances, complete from the main to the first flange above ground at the building.
- _____ E. Existing surface improvements, and utilities, which are near or across the new service line.
- _____ F. The location of the post indicator valve between the detector check valve and fire department connection; PIV to have a 4" column and two 2-1/2" ports.
- _____ G. Profile of the complete underground line, including the new riser to the first flange above ground. (see item IV)
- _____ H. The type and class of pipe to be used. (PVC water pipe, class 200, per AWWA Standard C-900).
- _____ I. Clearances between new line and existing lines are 5' (min.) horizontal clearance between parallel pipes, and 1' (min.) vertical clearance between crossing pipes.
- _____ J. Thrust block at each pipe joint to be deflected ten-degrees or greater; maximum joint deflection is 2 degrees.
- _____ K. Three feet (min.) cover from finished grade to new pipe.
- _____ L. Bore under existing curb and gutter for installing the new pipe.

_____ M. Show "Construction Notes" for the Underground Fire Service (with water meter) – attached.

II. Drawings shall contain references to applicable City Standard Details, including the following (as appropriate):

- _____ A. "Utility Trench Detail", UT-1, (see item 10)
- _____ B. "Thrust Blocks", W-7, (see item 10)
- _____ C. "Excavation for Tapping Sleeve and Valve", W-9
- _____ D. "Location Wire", W-10
- _____ E. "Valve Stem Extension", W-11
- _____ F. "Valve Box and Riser", W-12
- _____ G. "Detector Check Valve", W-13
- _____ H. Specification for "Trenching", "Coating and Lining", "Fittings", "Valves and Valve Boxes", "Sterilization", "Testing", "Locating Wires", etc.

III. If the structure is located on or east of El Camino Real, the following details must also be referenced on the drawings:

- _____ A. "Cathodic protection of fittings and valves", W-14, (2 sheets)
- _____ B. "Test station housing for cathodic protection", W-16
- _____ C. "Anode size and notes for cathodic protection", W-17
- _____ D. "Exothermic weld for cathodic protection", W-18
- _____ E. An insulation flange at the first flange above ground on the automatic sprinkler riser, to break the continuity of the cathodic protection.

IV. If the structure is located in an area with bay mud, then the following details must be shown or referenced on the mylar:

- _____ A. flexible connection of new service line in vault (to be prepared by designer).
- _____ B. "Utility Trench Detail", UT-2
- _____ C. "Thrust Blocks", W-8 (2 sheets)

**CONSTRUCTION NOTES
FOR THE UNDERGROUND FIRE SERVICE (WITH WATER METER)**

1. Call U.S.A. (800) 642-2444 at least 48 hours prior to start of work for utility location markings; remove temporary construction markings on pavement and sidewalks.
2. Call for inspection at least one full working day prior to start of work. Phone Redwood City Engineering at (650) 780-7380.
3. Contractor shall make arrangements with the City at least two working days prior to any tie-ins and any task in which participation by City forces is necessary; City water valves are operated by City forces only; wet tap (if any) by City only after a cost estimate is approved – and payment by contractor, owner or developer is made.
4. Contractor must use hand tools when excavating near existing underground utility lines; conform to CAL-OSHA standards for deep trench excavation and shoring.
5. Contractor shall provide cones, flagmen, barricades, delineators and warning devices – as necessary – to control traffic and prevent hazardous conditions; contractor shall cooperate with residences and establishments for use of their driveways. For traffic lane closure, conform to Caltrans Standard Plans, T-Series.
6. All underground fire services shall comply with the requirements of NFPA-24.
7. Contractor must make arrangements with the appropriate utility company prior to any tie-in, abandonment of or work with their facilities in the public right-of-way.
8. Each valve box and anode test station box shall be adjusted to grade in concrete before paving.
9. Contractor shall make arrangements with the City for sterilization testing; chlorination by contractor; sampling points selected by City. Samples must be collected by testing lab at the worksite with City representative present; one test lab report, with original signature, must be submitted to City Engineer.
10. Any existing improvements, utilities or pavement/curb markings damaged during construction shall be replaced and/or repaired to facility owner's satisfaction at the contractor's expense.
11. Any temporary water service or meter required during construction shall be paid for by the contractor.
12. Contractor shall conform to the "Standard Details and the Standard Technical Specifications of the City of Redwood City"

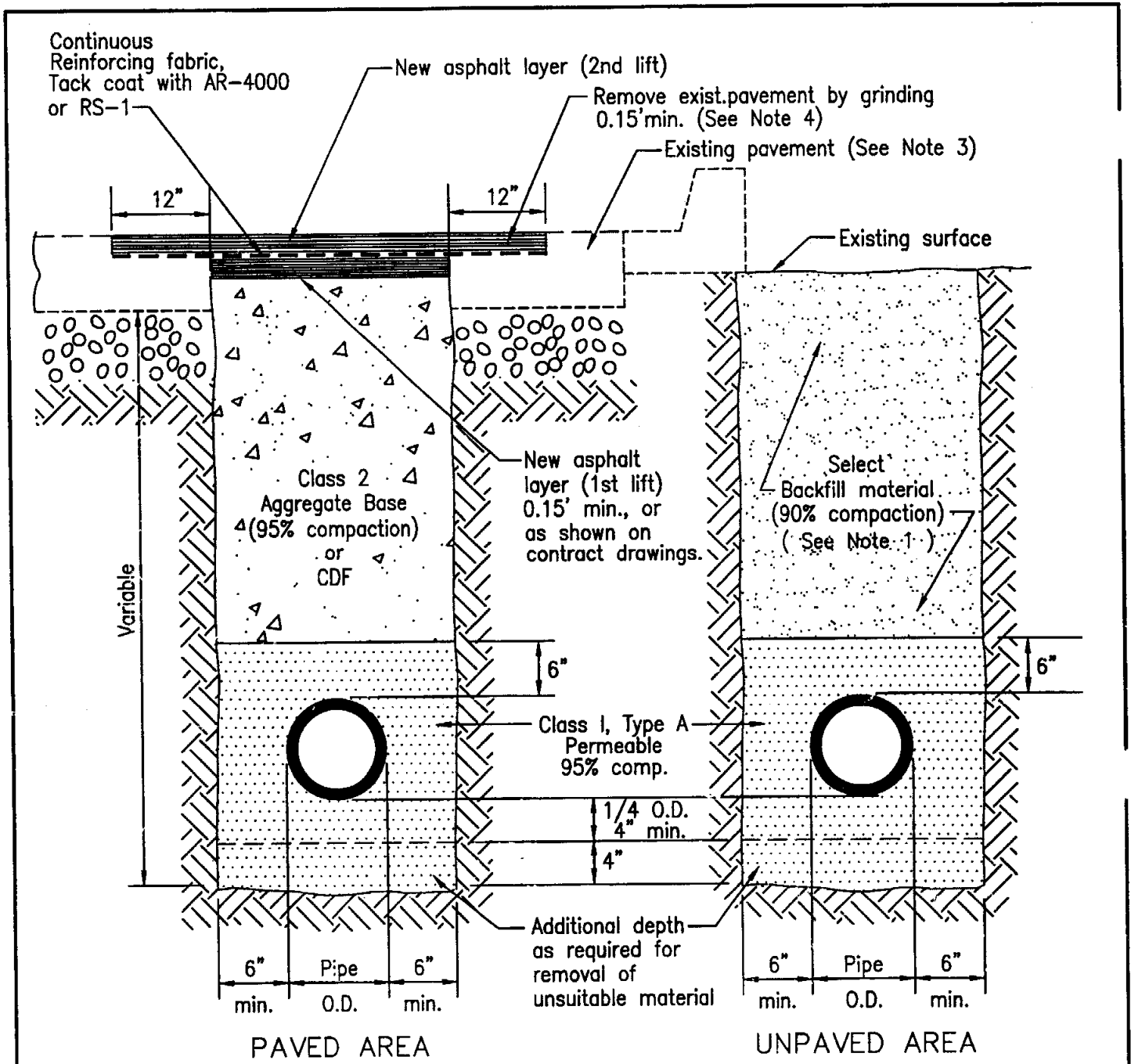

NOTES:

1. Select backfill material - material from excavation, free from stones or lumps exceeding 3" in greatest dimension, vegetable matter, or unsatisfactory material. (See Specifications)
2. For new streets use design structural section as shown on plans.
3. If the edge of the trench falls within 3' of the gutter, the entire pavement shall be removed.
4. If existing pavement is less than 3" thick, pavement edge shall be sawcut to full depth in lieu of grinding.

NOT TO SCALE

STANDARD DETAIL	CITY OF REDWOOD CITY ENGINEERING AND CONSTRUCTION	
DATE: 10/13/03	UTILITY TRENCH DETAIL	UT-1 SHT 1 OF 1

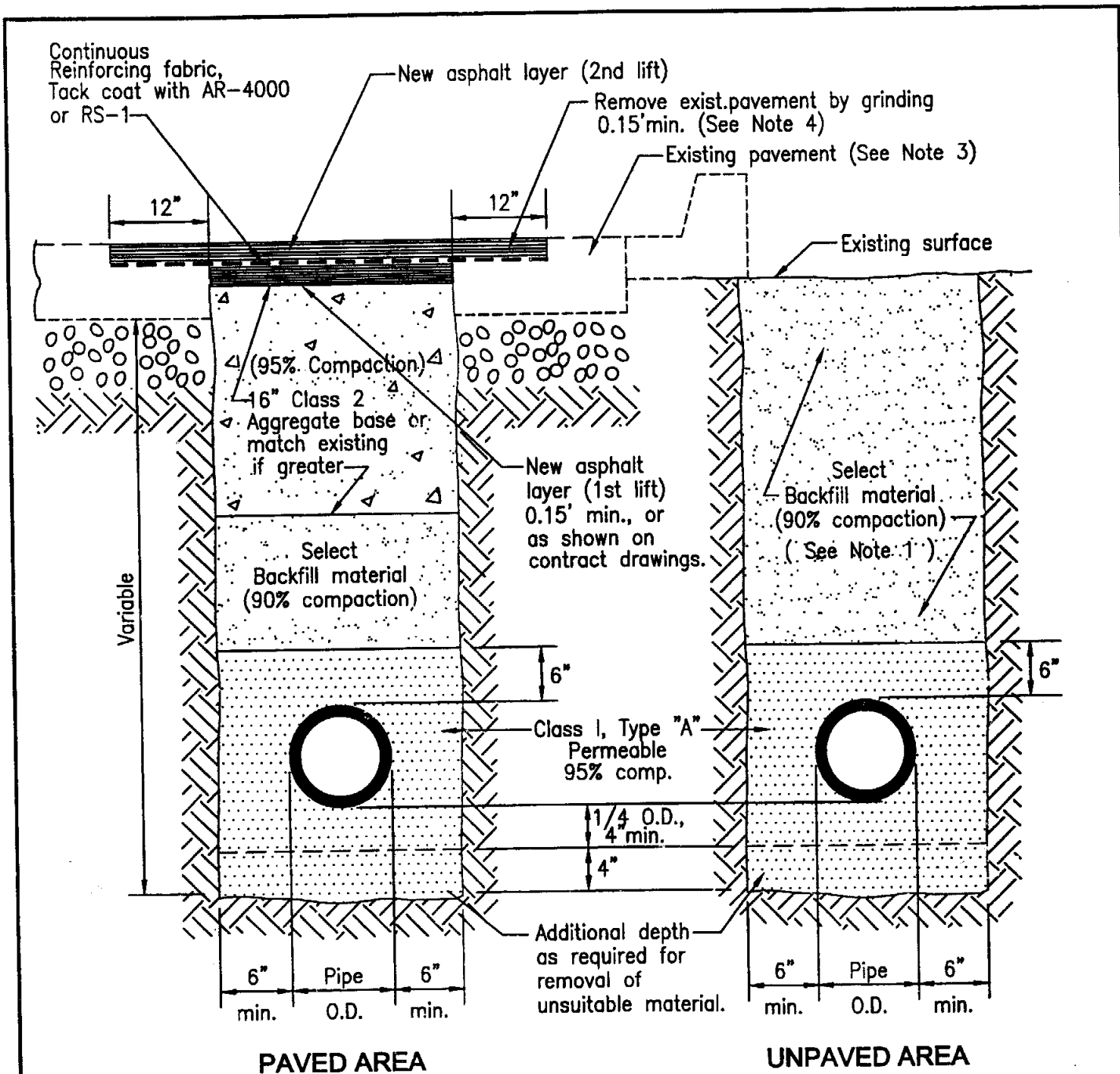

NOTES:

1. Select backfill material – material from excavation, free from stones or lumps exceeding 3" in greatest dimension, vegetable matter, or unsatisfactory material. (See Specifications)
2. For new streets use design structural section as shown on plans.
3. If the edge of the trench falls within 3' of the gutter, the entire pavement shall be removed.
4. If existing pavement is less than 3" thick, pavement edge shall be sawcut to full depth in lieu of grinding.

NOT TO SCALE

STANDARD DETAIL	CITY OF REDWOOD CITY ENGINEERING AND CONSTRUCTION	
	UTILITY TRENCH DETAIL (BAY MUD)	UT-2 SHT 1 OF 1
DATE: 10/13/03		

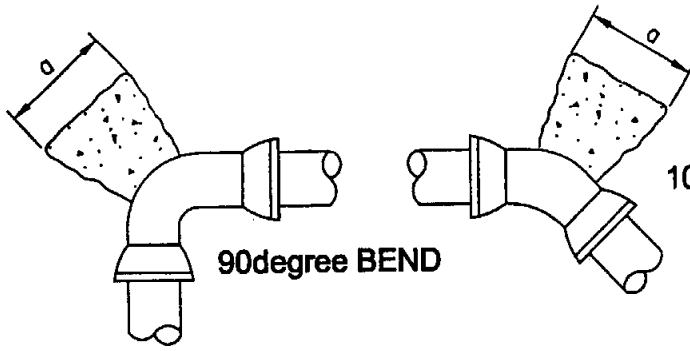

90degree BEND

10degree TO 45degree BENDS

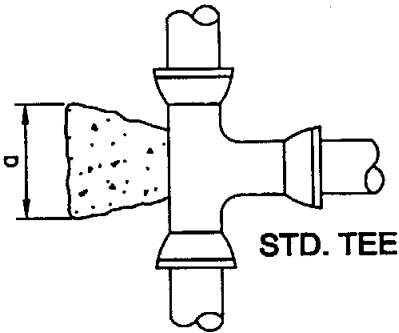

STD. TEE

PLUGGED CROSS

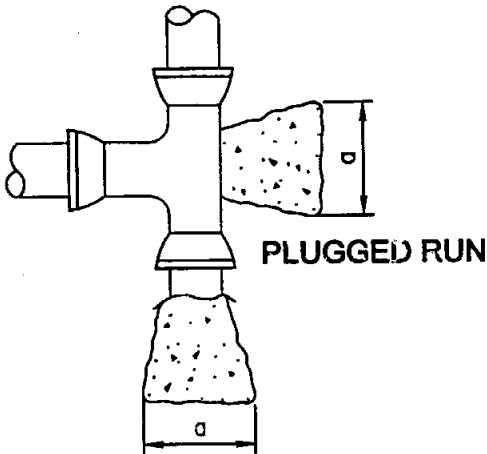
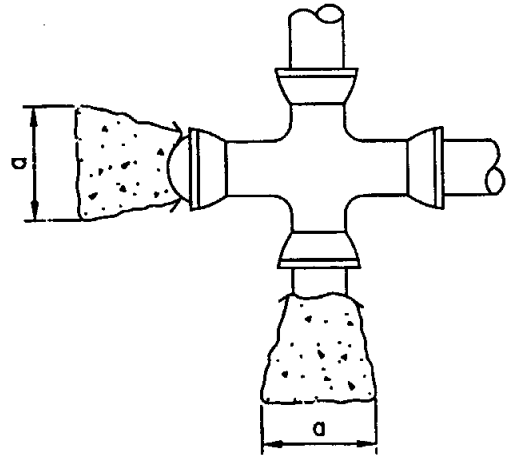

PLUGGED RUN

NOTE:

1. All Thrust Blocks shall bear against undisturbed Earth.

AREA (a) IN SQ. FT.

TYPE OF FITTING	SIZE OF PIPE							
	4"	6"	8"	10"	12"	14"	16"	18"
90° ELL	2	5	8	13	18	25	32	41
45° ELL	1	3	5	7	10	14	18	22
22 1/2° ELL	1	2	3	4	5	7	9	12
11 1/4° ELL	1	1	2	2	3	4	5	6
PLUG/TEE	1.5	4	6	9	13	18	23	29

Based on Soil bearing value of 2000 lbs. per sq. ft. and water pressure of 225 psi form as required to keep concrete off of mechanical joint or flange bolts.

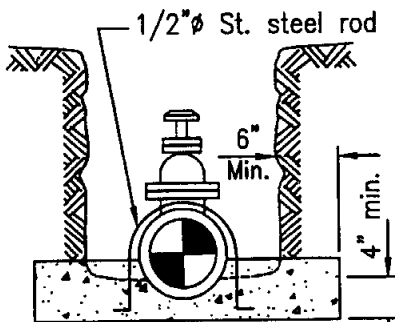

GATE VALVE

NOT TO SCALE

STANDARD
DETAIL

CITY OF REDWOOD CITY
ENGINEERING AND CONSTRUCTION

DATE: 10/13/03

THRUST BLOCKS

W-7
SHT 1 OF 1

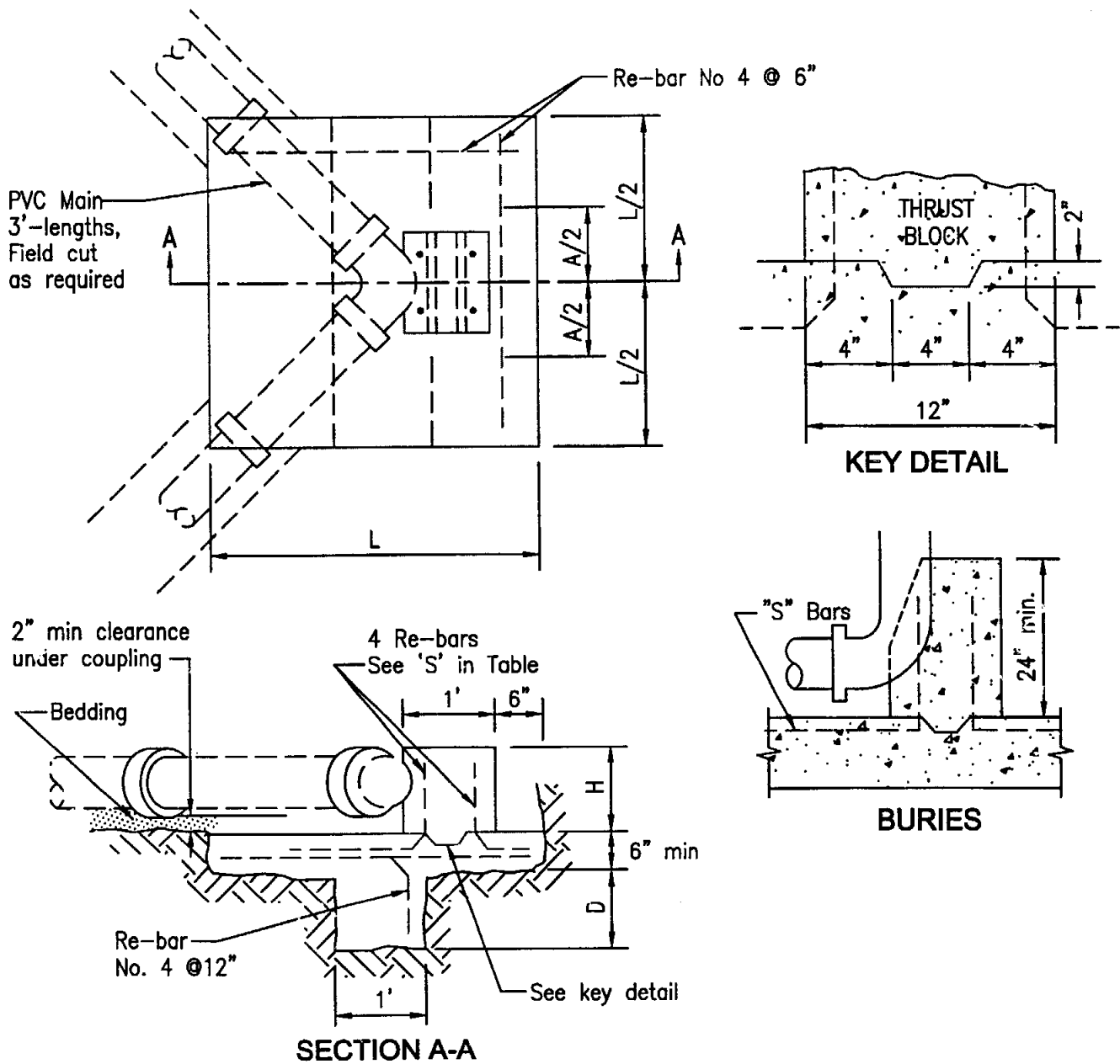

DIMENSION TABLE FOR HORIZONTAL BENDS

PIPE DIAMETER	90 deg Bend					45 deg Bend					22 deg 30' Bend					11 deg 15' Bend				
	A	D	H	L	RE-BAR 'S' SIZE	A	D	H	L	RE-BAR 'S' SIZE	A	D	H	L	RE-BAR 'S' SIZE	A	D	H	L	RE-BAR 'S' SIZE
6"	15"	12"	12"	4'	No. 4	10"	12"	12"	3'	No. 4	8"	6"	12"	3'	No. 4	7"	6"	12"	3'	No. 4
8"	18"	12"	14"	4'	No. 4	12"	12"	14"	4'	No. 4	9"	6"	14"	3'	No. 4	8"	6"	14"	3'	No. 4
10"	23"	24"	16"	5'	No. 5	13"	12"	16"	4'	No. 5	11"	12"	16"	4'	No. 4	9"	6"	16"	3'	No. 5
12"	26"	36"	18"	5'	No. 6	15"	24"	18"	4'	No. 5	13"	12"	18"	4'	No. 4	10"	6"	18"	4'	No. 5

NOT TO SCALE

STANDARD
DETAIL

CITY OF REDWOOD CITY
ENGINEERING AND CONSTRUCTION

DATE: 10/13/03

THRUST BLOCKS
(IN BAY MUD)

W-8
SHT 1 OF 2

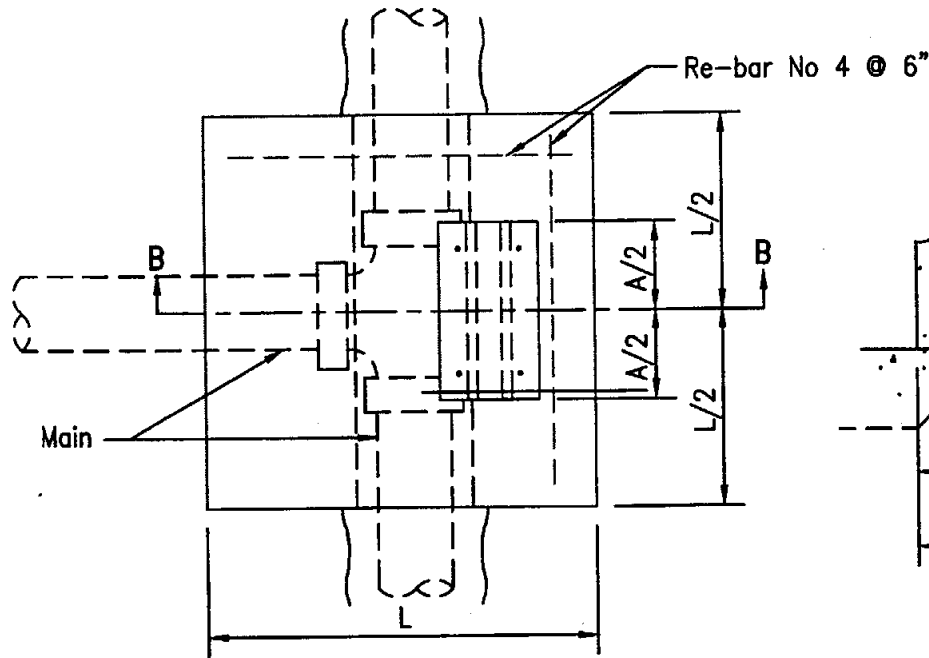

PLAN

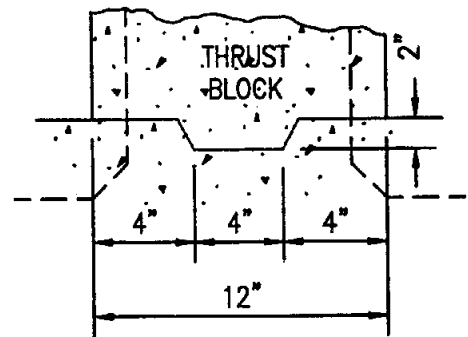

KEY DETAIL

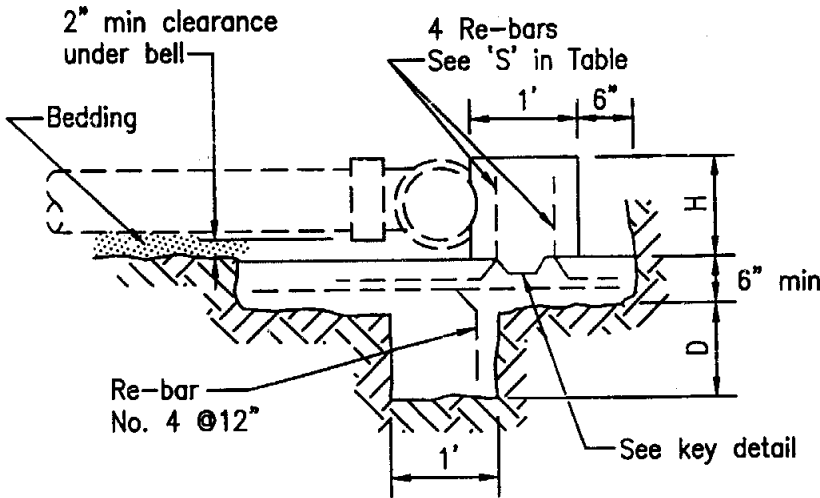

SECTION B-B

NOTES:

1. All FITTING JOINTS will be clear of all concrete.
2. Concrete shall be Class "A".
3. Use 3' lengths of pipe one each side every fitting.

DIMENSION TABLE FOR TEE & DEAD ENDS						
PIPE DIAMETER	TEE A	DEAD END A	D	H	L	RE-BAR 'S' SIZE
6"	16"	8"	12"	12"	4'	No. 4
8"	18"	10"	12"	14"	4'	No. 4
10"	22"	12"	24"	16"	4'	No. 5
12"	24"	14"	36"	18"	5'	No. 6

NOT TO SCALE

STANDARD
DETAIL

CITY OF REDWOOD CITY
ENGINEERING AND CONSTRUCTION

DATE: 10/13/03

THRUST BLOCKS
(IN BAY MUD)

W-8
SHT 2 OF 2

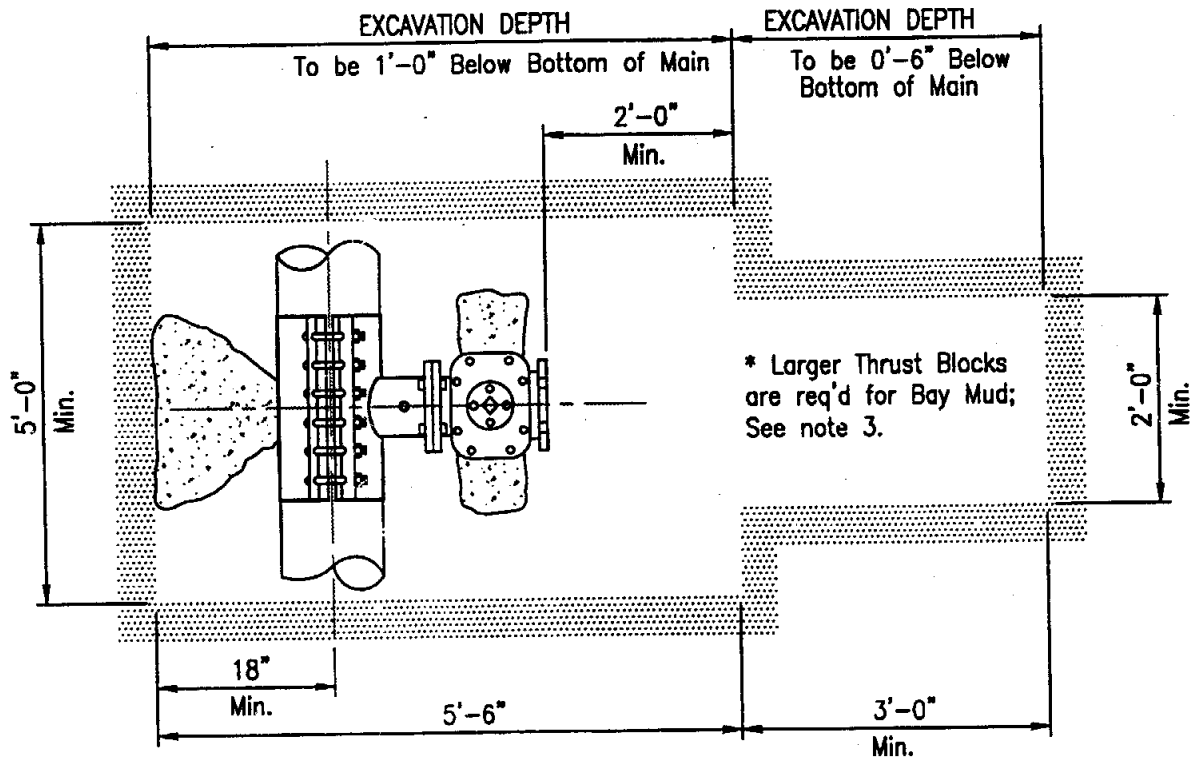

NOTE:

1. No tap to be made within 30" of a joint or fitting on C.I.P. or D.I.P.
2. Tap on AC and P.V.C. pipe shall be made 3' minimum from any coupling or fitting.
3. Contractor to install thrust block behind and under tapping sleeve and For Bay Mud Conditions concrete pad under valve, per detail W-8.
4. The Contractor supplies the material and The City makes the wet tap.
5. Tapping Sleeves shall be Smith Blair 663-316SS, JCM 432-SS316 all 316 stainless steel or approved equal; and Tapping Valves shall be Mueller flange x mechanical joint or approved equal.
6. When cathodic protection is required, do not connect bond cables to a stainless steel tapping sleeve.

NOT TO SCALE

**STANDARD
DETAIL**

**CITY OF REDWOOD CITY
ENGINEERING AND CONSTRUCTION**

DATE: 10/13/03

**EXCAVATION FOR TAPPING
SLEEVES & VALVES**

**W-9
SHT 1 OF 1**

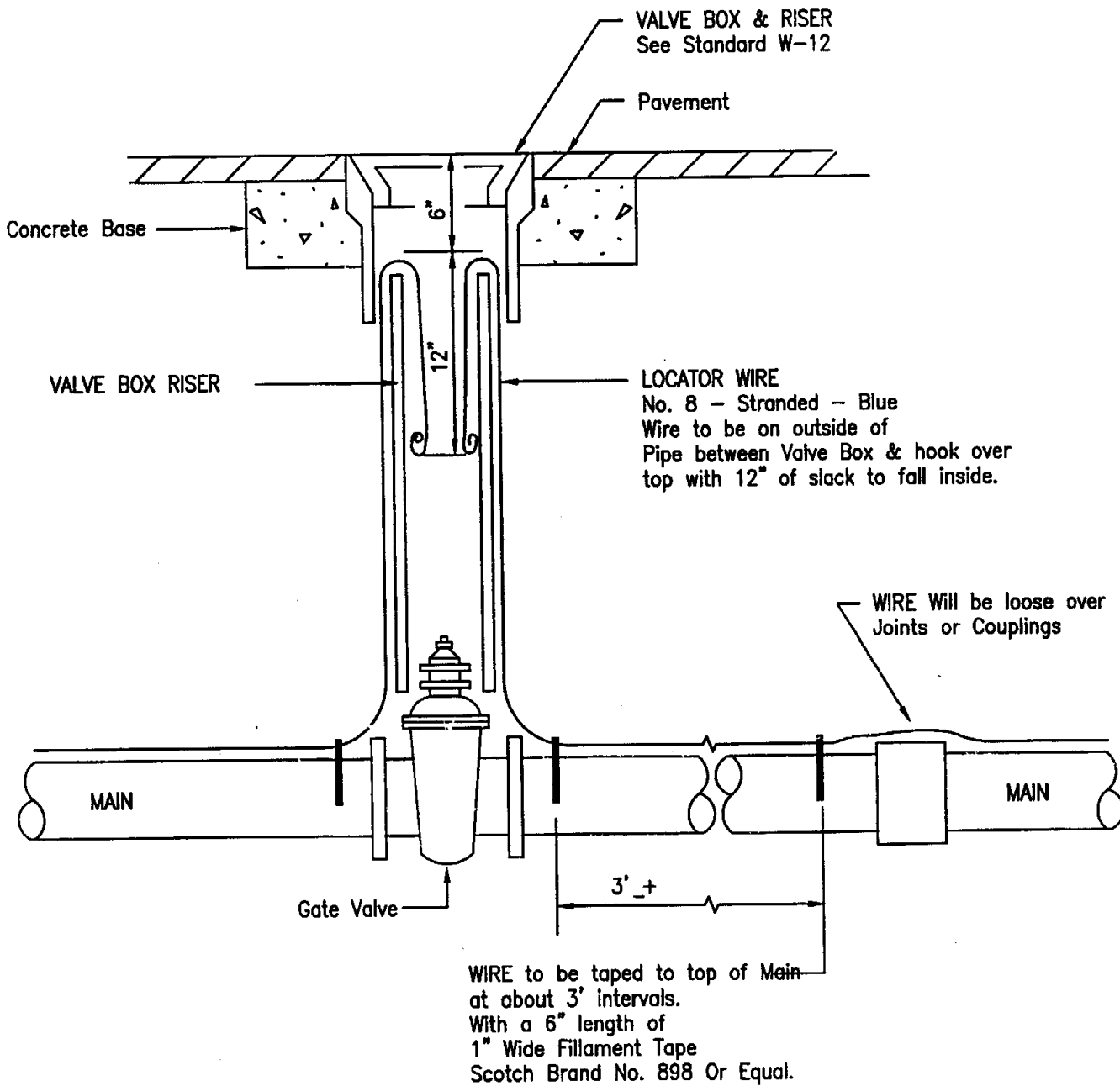

NOT TO SCALE

**STANDARD
DETAIL**

**CITY OF REDWOOD CITY
ENGINEERING AND CONSTRUCTION**

DATE: 10/13/03

LOCATOR WIRE

**W - 10
SHT 1 OF 1**

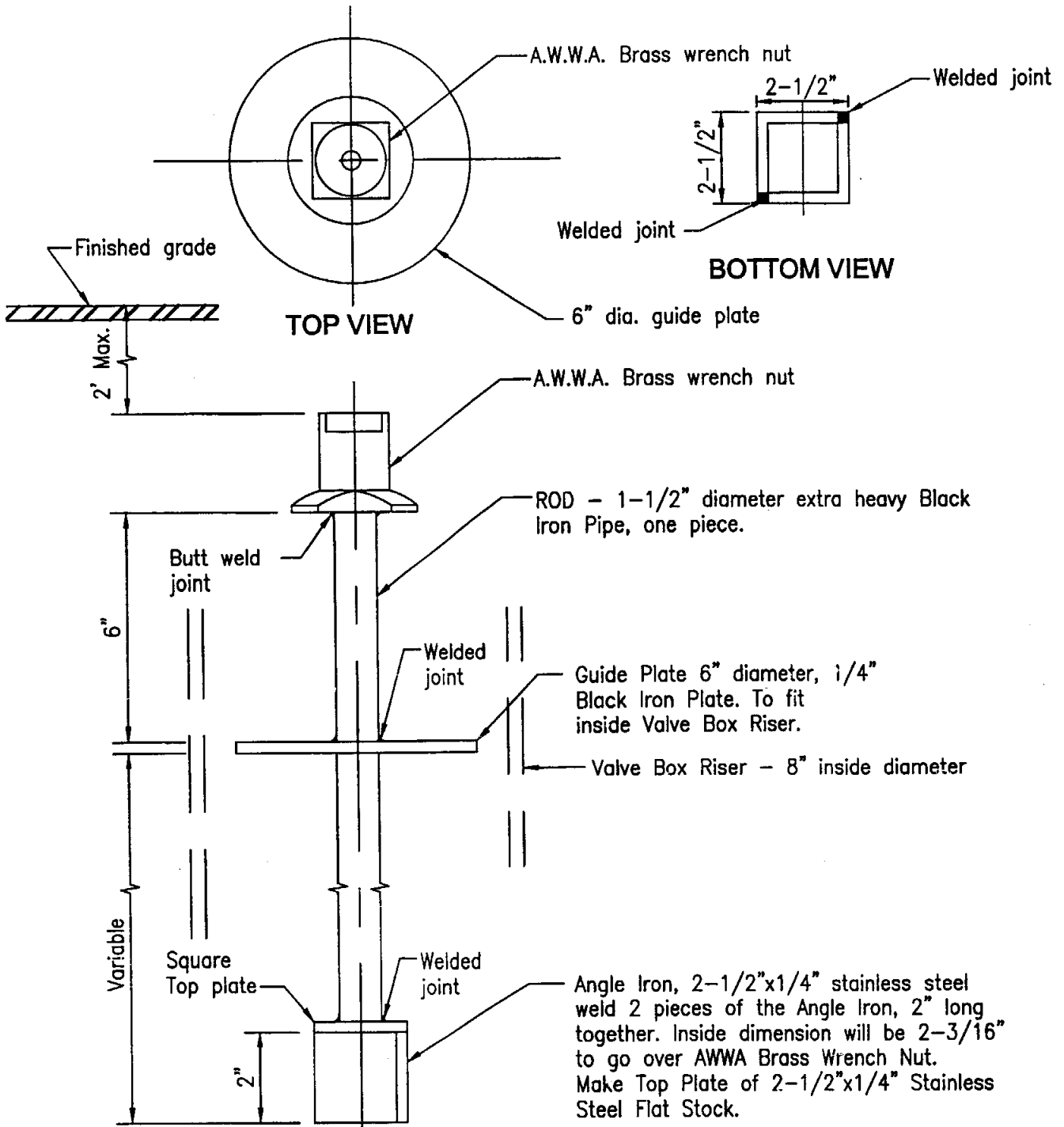

NOTES:

1. Extensions are required for valves extending for more than 4 feet below the surface.
2. After assembly the Valve Stem will be Fusion Coated per Standard Specifications.

NOT TO SCALE

STANDARD DETAIL	CITY OF REDWOOD CITY ENGINEERING AND CONSTRUCTION	
	VALVE STEM EXTENSION	W - 11 SHT 1 OF 1
DATE: 10/13/03		

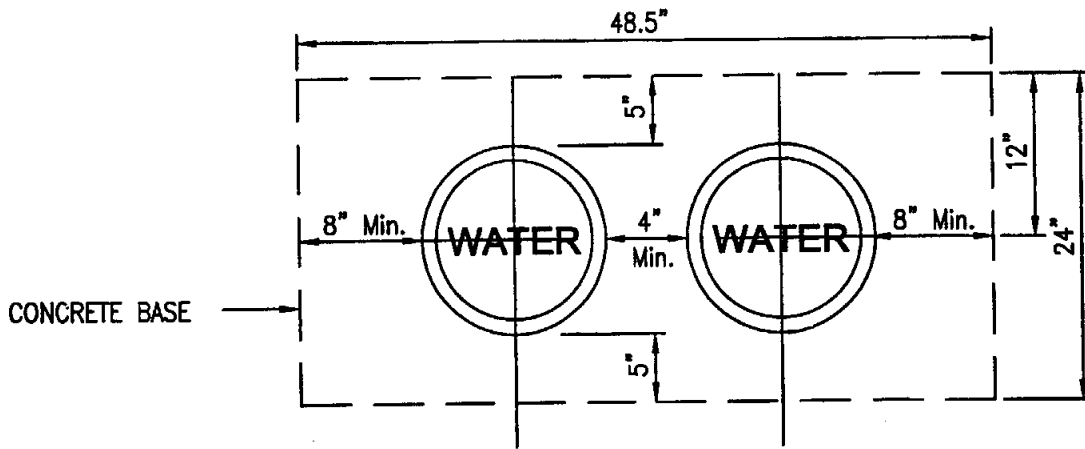

DOUBLE VALVE BOX

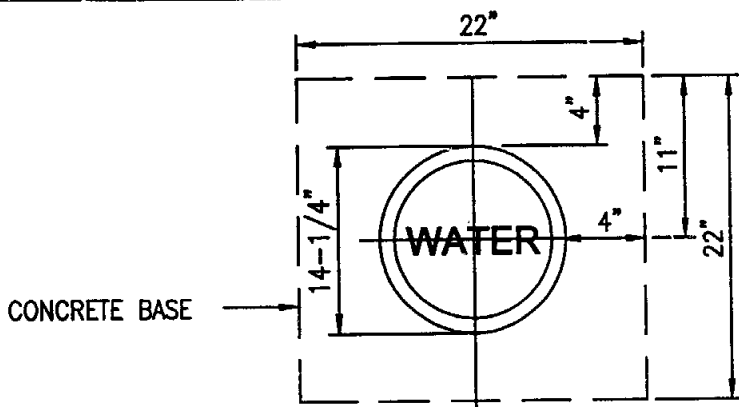
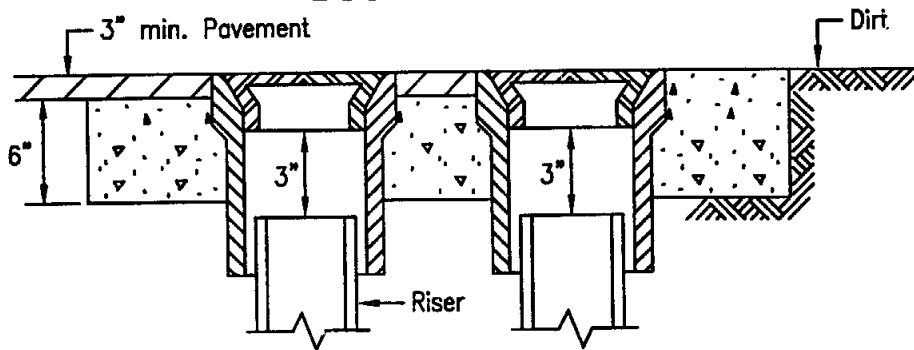

SINGLE VALVE BOX

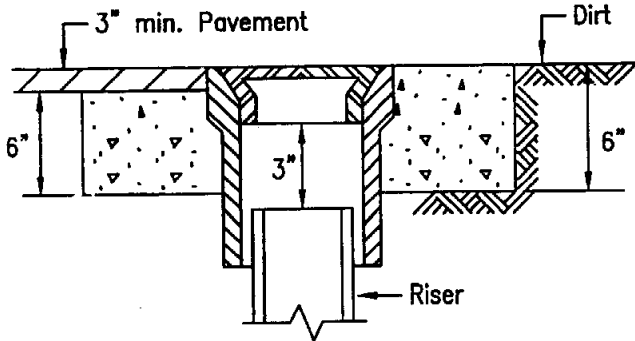

NOTE:

- VALVE BOX - Christy Type G5 Box or equal
- COVER - Each Cover shall have cast into it the letters "WATER"
- RISER - Will be of one piece 8" PVC Pipe
- CONCRETE - Class A
- VALVE BOX IN DIRT - Set Valve Box, install concrete base even with surface

NOT TO SCALE

**STANDARD
DETAIL**

**CITY OF REDWOOD CITY
ENGINEERING AND CONSTRUCTION**

DATE: 10/13/03

VALVE BOX & RISER

**W-12
SHT 1 OF 1**

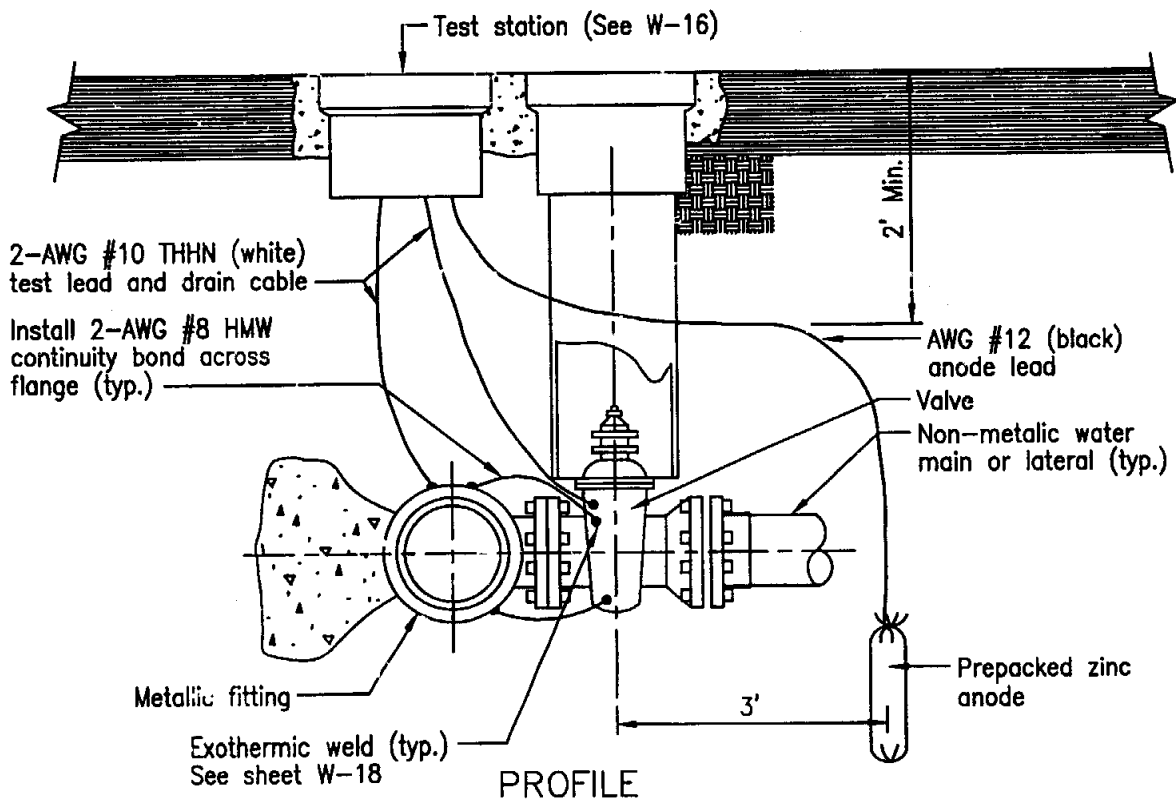
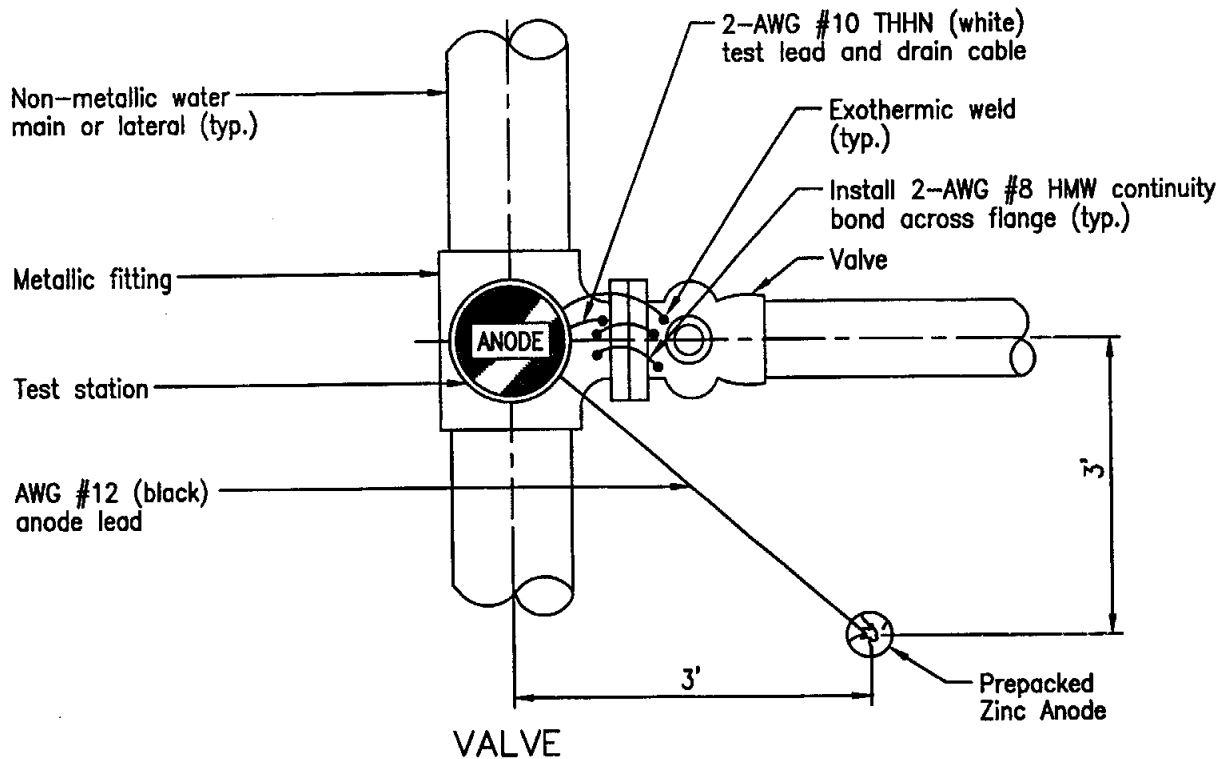

NOTE:

- Contractor shall not bring up any cathodic protection wires in valve box.

NOT TO SCALE

**STANDARD
DETAIL**

CITY OF REDWOOD CITY
ENGINEERING AND CONSTRUCTION

DATE: 10/13/03

**CATHODIC PROTECTION
AT FITTINGS & VALVES**

W-14
SHT 1 OF 2

Push-on, metal cross fitting

Non-metallic water main or lateral (typ.)

2-AWG #10 THHN (white) test lead and drain cable

Exothermic weld (typ.)

3'

3' Length PVC (Typical)

Valve (Typical)

AWG #12 (black) anode lead

Test station
Install 2-AWG #8 continuity bond across flange (typ.)

Prepacked Zinc Anode (Size per Detail W-3034)

TEE / CROSS

Non-metallic water main or lateral (typ.)

Test station

AWG #12 (black) anode lead

Prepacked zinc anode

Push-on, Metallic fitting

2-AWG #10 THHN (white) test lead and drain cable

BEND

NOT TO SCALE

STANDARD
DETAIL

CITY OF REDWOOD CITY
ENGINEERING AND CONSTRUCTION

DATE: 10/13/03

CATHODIC PROTECTION
AT FITTINGS & VALVES

W-14
SHT 2 OF 2

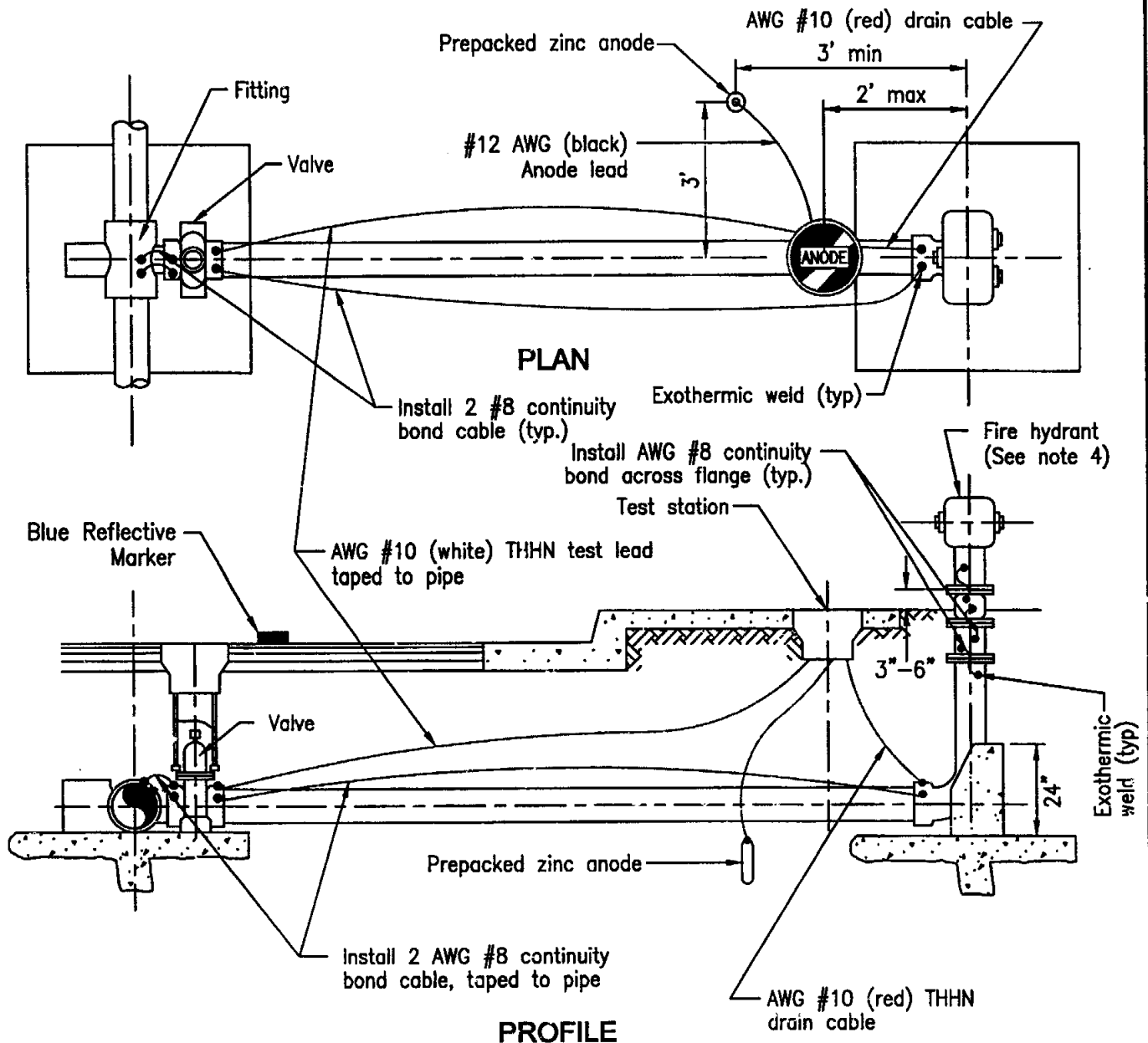

NOTES:

1. Contractor shall follow the listed wire schedule: Fitting test lead - AWG #10 white; Anode test lead - AWG #12 black; Hydrant drain cable - AWG #10 red.
2. See sheet W-17 for Anode size and construction requirements.
3. See sheet W-8 for Thrust Block sizes and dimensions.
4. Fire Hydrant shall be Clow, low-silhouette Model #92 with two 2-1/2" and one 4-1/2" outlets, fusion epoxy lined and coated.

NOT TO SCALE

STANDARD DETAIL	CITY OF REDWOOD CITY ENGINEERING AND CONSTRUCTION	
	FIRE HYDRANT (IN BAY MUD)	W-15 SHT 1 OF 1
DATE: 10/13/03		

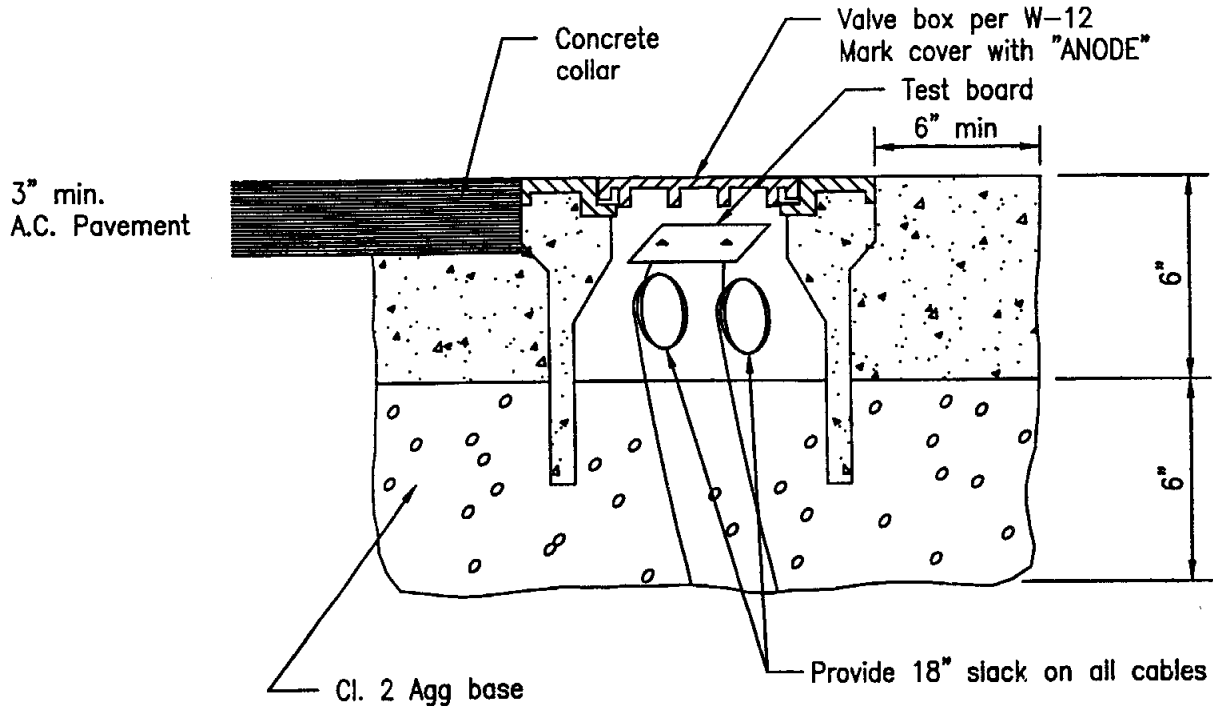

TEST STATION HOUSING DETAIL

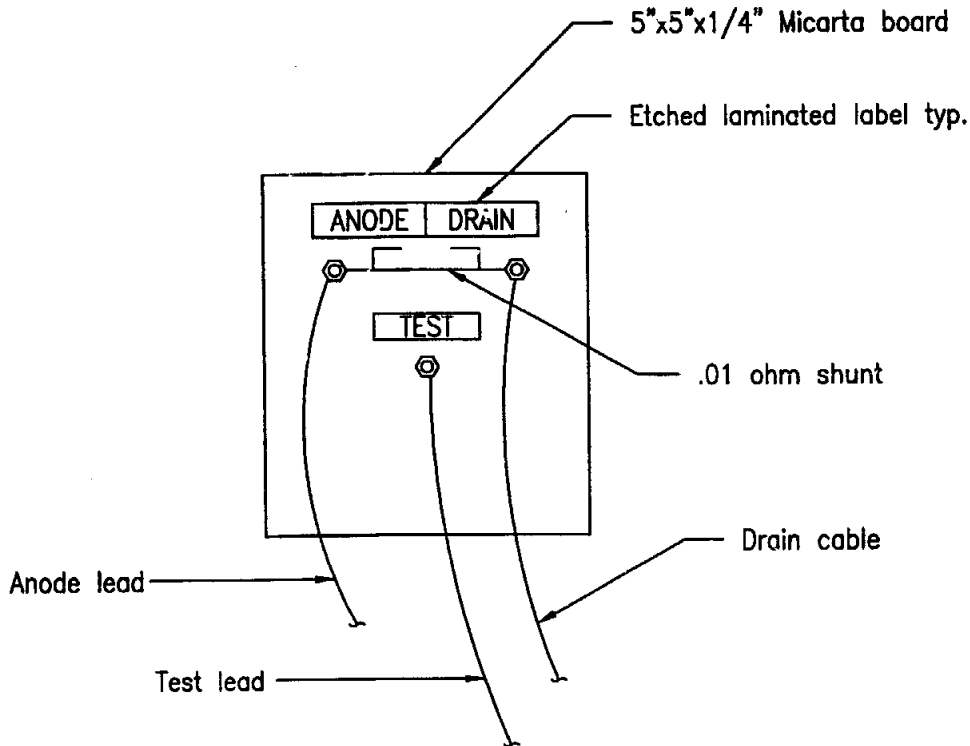

TEST TERMINAL BOARD DETAIL

NOT TO SCALE

STANDARD DETAIL	CITY OF REDWOOD CITY ENGINEERING AND CONSTRUCTION	
	CATHODIC PROTECTION TEST STATION HOUSING	W-16 SHT 1 OF 1
DATE: 10/13/03		

REQUIRED ANODE SIZE (IN LBS)*							
PIPE SIZE	VALVE	CROSS**	TEE**	ELBOW	Rt. xFlg ADAPTER	FIRE HYDRANT & BURY	PER 36" OF SPOOL LENGTH
4"	1.2	1.5	1.2	1	0.5	-	1
6"	1.8	2.3	1.8	1.5	0.8	3	1.5
8"	2.4	3	2.4	2	1	-	2
10"	3	3.8	3	2.5	1.3	-	2.5
12"	3.6	4.5	3.6	3	1.5	-	3
14"	4.2	5.3	4.2	3.5	1.75	-	3.5
16"	4.8	6.0	4.8	4.0	2.0	-	4.0

* Minimum bare zinc anode weight per installation is 5lbs (see note)
 ** Base weight required on largest outlet

NOTES:

1. When a zinc anode greater than 5lbs in weight is required it shall be sized for the weight of a standard zinc anode as follows:
5lbs, 15lbs, 33lbs, 66lbs.

NOT TO SCALE

STANDARD DETAIL	CITY OF REDWOOD CITY ENGINEERING AND CONSTRUCTION	
	CATHODIC PROTECTION ANODE SIZE AND NOTES	W-17 SHT 1 OF 1
DATE: 10/13/03		

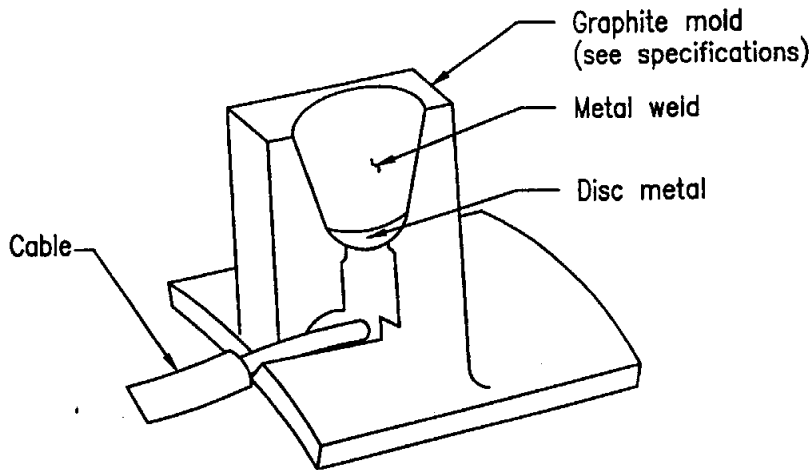

MOLD DETAIL

STEPS:

1. File to bare metal & clean over surface

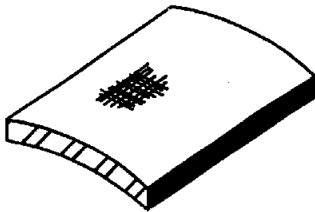

2. Strip insulation from wire and attach copper sleeve

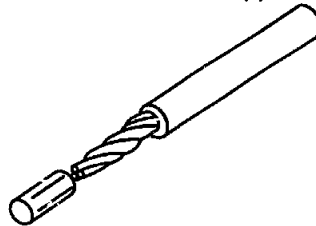

3. Hold mold firmly with opening away from operator ignite with flint gun.

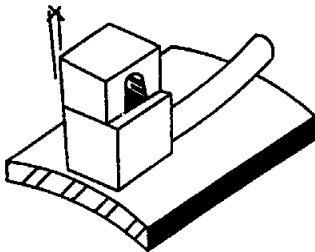

4. Remove slag from connection, cover connection with compatible coating over metal all exposed.

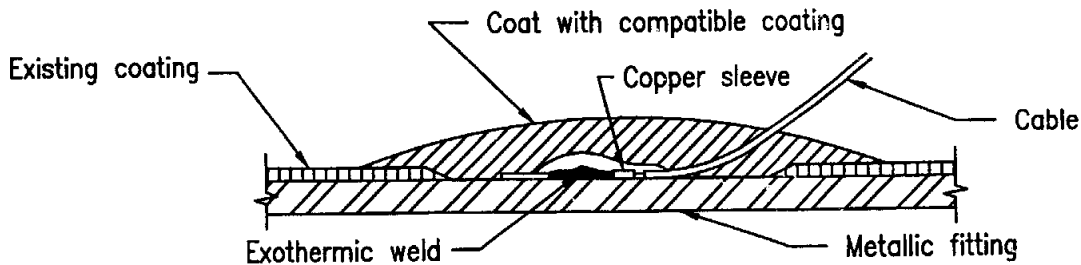
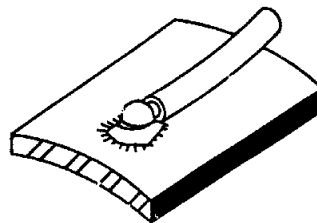

NOT TO SCALE

**STANDARD
DETAIL**

**CITY OF REDWOOD CITY
ENGINEERING AND CONSTRUCTION**

DATE: 10/13/03

**CATHODIC PROTECTION
EXOTHERMIC WELD**

**W-18
SHT 1 OF 1**

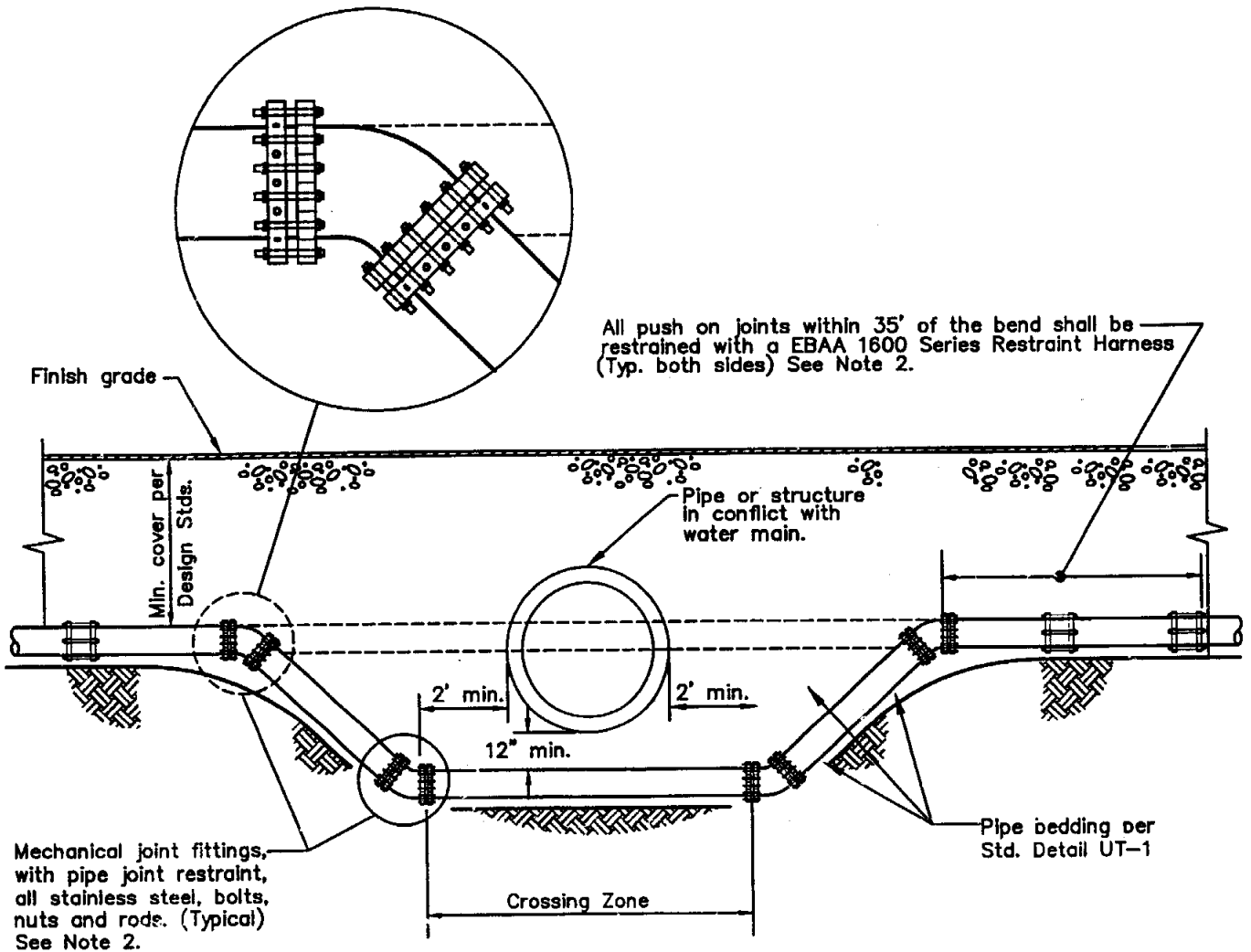

All push on joints within 35' of the bend shall be restrained with a EBAA 1600 Series Restraint Harness (Typ. both sides) See Note 2.

NOTES:

1. All bends shall be 45° or 22-1/2° fittings, as required for proper horizontal separation.
2. For PVC Pipe, mechanical joint restraints shall be EBAA Series 2000; for DIP, mechanical joint restraints shall be EBAA Series 1100; for DIP push on joints use US Pipe Field-Lok 350 gaskets.
3. The crossing zone, applies to a water line crossing underneath a sewer line. No joints are permitted for 10' on either side of the sewer line in this zone.

NOT TO SCALE

STANDARD DETAIL	CITY OF REDWOOD CITY ENGINEERING AND CONSTRUCTION	
DATE: 10/13/03	WATER MAIN LOWERING DETAIL	W-20 SHT 1 OF 1

SECTION 02660
WATER SYSTEMS

PART 1 - GENERAL

1.01 WORK INCLUDED

- A. Trenching and other excavation.
- B. Ground water control.
- C. Pipe bedding.
- D. Installation of water lines and appurtenances.
- E. Backfill and compaction of backfill.
- F. Sterilization and testing.
- G. Dust alleviation and control.
- H. Cleanup and restoration of surface in improved areas.
- I. Supplying all labor, materials, equipment and apparatus not specifically mentioned herein or noted on the plans, but which are incidental and necessary to complete the work specified.

1.02 APPLICABLE PUBLICATIONS

- A. The publications listed below form a part of this specification to the extent referenced. The publications are referenced in the text only by their general designation only.
- B. American Society for Testing and Materials (ASTM) Publications:
 - A - 276 Standard Specification for Stainless and Heat-Resisting Steel Bars and Shapes.
 - D - 2737 Specification for Polyethylene (PE) Plastic Tubing.
 - F - 477 Elastomeric Seals (Gaskets) for joining Plastic Pipe.
- C. American Water Works Association (AWWA) Publications
 - C-153 Ductile-Iron Fittings 3" through 48" for Water and Other Liquids.
 - C - 111 Rubber Gasket Joints for Ductile Iron and Gray-Iron Pressure Pipe and Fittings.

- C - 502 Dry Barrel Fire Hydrants.
- C - 503 Standard for Wet-Barrel Fire Hydrant.
- C - 504 Rubber-sealed Butterfly Valves.
- C - 509 Resilient Seated Gate Valves, 3 through 12 NPS for Water and Sewage Systems.
- C - 550 Protective Epoxy Interior Coatings for Valves and Hydrants.
- C - 601 Disinfecting Water Mains.
- C - 900 Polyvinyl Chloride (PVC) Pressure Pipe, 4" through 12" for Water.
- C - 905 Polyvinyl Chloride (PVC) Water Transmission Pipe, Nominal Diameters 14" through 36".

1.03 QUALITY ASSURANCE

- A. Water mains, services and appurtenances shall be subject to hydrostatic and leakage tests.
- B. Water mains, services, and appurtenances shall be sterilized prior to connection to existing systems.
- C. Submit manufacturer's data on the pipe material, fittings, valves and service material.
- D. The maximum allowable deflection (out of roundness) of PVC pipe under superimposed loads, shall be 5%, or 75% of the manufacturers recommended maximum, whichever is smaller.
- E. The Engineer may require manufacturer's certificates showing conformance with this specification for any of the pipe materials, fittings, valves and appurtenances delivered to the job site.
- F. For Fire Service lines, the lines shall be subject to a high velocity flushing test. Methods of flushing shall be approved in advance by the Engineer.

1.04 JOB CONDITIONS

- A. Comply and conform with conditions and requirements indicated and specified under Section 02202 of these specifications.

PART 2 - PRODUCTS

2.01 PIPE MATERIALS

- A. Water mains 12" in diameter or less shall be PVC pressure pipe conforming to the applicable requirements of AWWA Specification C900 for class 200 pipe

having a dimension ratio (DR) of 14 and a cast iron pipe equivalent outside diameter.

- B. Pipes 14" in diameter or larger shall be PVC transmission pipe conforming to AWWA C905, having a DR of 18 and cast iron pipe equivalent outside diameter.
- C. Maximum length of each section of pipe between elastomeric rings shall be twenty (20) feet.
- D. Each length of pipe shall have the words "DOMESTIC WATER" stenciled with 1-5/8" high lettering in permanent ink, at 2-foot spacing along its length.
- E. The Contractor may substitute pressure-sensitive tape in lieu of stenciling. Adhesive Backed Pipe Labeling Tape shall be PVC Plastic tape manufactured specifically for direct placement onto pipe, cable or conduit for warning and identification. Tape shall be a minimum of 2.2 mils, an adhesive strength of 26 psi, and with tensile strength of 32 lb. per inch of width. Tape shall be of the type provided in rolls, color coded for the utility involved with warning and identification imprinted in bold letters continuously and repeatedly over entire tape length. Code and letter coloring shall be permanent, unaffected by moisture or other substances contained in trench material.

2.02 PIPE COUPLINGS

- A. All couplings for use on PVC pipe for water lines shall be manufactured from the same materials and in compliance with the specifications set forth herein before for PVC pipe for water lines. Each coupling shall be equipped with two rubber rings, which fit into individual grooves formed in the inner wall of the coupling to eliminate blowouts or leaks.
- B. Rubber rings for use with PVC pipe couplings, fittings and appurtenances shall be manufactured from properly vulcanized rubber compounds to a uniform cross-section free from porosity, pits and blisters in conformance with the requirements of ASTM Designation F-477.

2.03 FITTINGS

- A. Fittings for use on PVC pressure pipe shall be ductile iron castings conforming to the applicable requirements of AWWA Standard C153 for two-hundred fifty (250) psi working pressure. Joints shall be rubber gasketed per AWWA C-111.
- B. Tapping sleeves shall be Smith Blair 663-316 SS, JMC 432-SS316 or approved equal, all 316 stainless steel, with flat-faced flange to mate with standard tapping valves, with 3/4" NPT test plug.
- C. Fittings shall be fusion-epoxy lined and coated as specified in Section 02661 of these Specifications.
- D. All bolt-up sets (nuts, bolts and washers) and tie rods for valves, fittings and buries shall be stainless steel, ASTM A-276 Type 316.

- E. Air release valves shall be Cla-Val model 36 combination air release and vacuum valves with bronze trim or approved equal.

2.04 VALVES AND VALVE BOXES

- A. Gate valves shall conform to the requirements of AWWA C509 for resilient-seated valves. Stems shall be, fitted with a 2" x 2" square wrench nut and shall be manufactured to open counter-clockwise. Stem extensions shall be installed to bring the operating nut to within two (2) feet of finish grade where the depth from finished grade to operating nut exceeds four (4) feet. Gate valves shall be used for all valves ten (10) inches and smaller and shall be FUSION EPOXY lined and coated in conformance with the requirements of Section 02661 of these Specifications.
- B. Butterfly valves shall comply with the latest revision of AWWA Standard C504, Class 150-B having Cast Iron Bodies, Cast or Ductile Iron discs, Stainless Steel Shafts, adjustable field replaceable rubber seats mating against Stainless Steel seat rings, and field-replaceable seals. End connections shall be flanged or Mechanical Joint. Wafer type valves shall not be allowed. Valve actuators shall be of the traveling nut type designed for buried service, sized to operate the valves against 150 psi unbalanced line pressure, with field adjustable and stops capable of withstanding input torque of 450 ft. lbs. All internal and external surfaces of butterfly valves shall be covered with a factory applied 2-part, polyamide cured, epoxy coating applied over a sand blasted "near white" metal surface per SSPC-SP10 to a minimum of 8 mils and a maximum of 12 mils, in compliance with AWWA Standard C550.
- C. Square wrench nut shall be brass and all other nuts, bolts, and washers throughout the valve and valve body shall be stainless steel, ASTM A-276, Type 316.
- D. Valves shall be provided with traffic valve boxes and cast iron traffic covers with "water" canted thereon, set in a concrete base as shown and dimensioned on the detail therefore on the plans.

2.05 WATER SERVICES

- A. Commercial water service lines four (4) inches in diameter and larger shall be PVC pressure pipe and couplings conforming to the requirements of AWWA Standard C900 for Class 200 pipe and couplings as herein specified for PVC pressure water mains.
- B. Commercial, irrigation, and residential water service lines two (2) inches in diameter or less, shall be polyethylene Plastic Pipe Class 200, conforming to the requirements of ASTM Designation D2737 for the size indicated on the plans.
- C. Fittings, couplings and water service material shall be bronze and all nipples shall be brass of the size and type called for on the plans.
- D. Water meters and detector meters shall be purchased from and installed by the City of Redwood City, unless otherwise shown.

- E. Meter box shall be provided for each water meter as shown on the plans, and shall conform to the size shown on the City Standard Details.

2.06 FIRE HYDRANTS

- A. All fire hydrant service runs shall be PVC pressure pipe as herein specified and shall be six (6) inches in diameter.
- B. Fire hydrant assemblies shall consist of a six (6) inch gate valve, the run of six (6) inch pipe, cast-iron bury, and the hydrant. Break off bolts shall be used to fasten the hydrant to the bury.
- C. Fire Hydrants shall be one of the four (4) different types depending on location and the size of the watermain.
 1. Type A - Mueller A-423 dry barrel or approved equal fusion epoxy lined and coated; provided with two 2-1/2" and one 4-1/2" outlets, conforming to AWWA C502.
 2. Type B - Clow 92 low silhouette, wet barrel or approved equal fusion epoxy lined and coated; provided with two 2-1/2" and one 4-1/2" outlets, conforming to AWWA C503.
 3. Type C - Clow 76 wet barrel or approved equal fusion epoxy lined and coated; provided with two 2-1/2" and one 4-1/2" outlets, conforming to AWWA C503.
 4. Type D - Clow 865 wet barrel or approved equal fusion epoxy lined and coated; provided with one 2-1/2" and two 4-1/2" outlets, conforming to AWWA C503.
- D. All exterior metal parts of the hydrant from the ground up shall be painted with two coats of paint, or one coat of primer and one coat of paint, in either Redwood Shores "DOLPHIN BLUE" or City Standard "LIME YELLOW", (DTM Mid Tone Base B66W102 enamel and #B66W1 primer), as appropriate to the location. Both paint colors are available from Sherwin Williams Company.
- E. Wet barrel fire hydrants, burys and break-off spools shall be epoxy lined and coated as herein specified for fittings.
- F. All fire hydrant heads, burys and extension spools shall be bolted with stainless steel bolts, and washers, as herein specified for fittings.

2.07 LOCATING WIRE

- A. Locating wire for use with plastic pipe installations shall be stranded copper, eight (8) gauge type TW or THHN electrical wire with solid blue jacket.
- B. Connect locating wire to metallic fittings with brass wire split nuts.

2.08 CONCRETE FOR THRUST BLOCKING

- A. Reinforcement for concrete thrust blocking shall be deformed steel bars conforming to Section 02550 of these Specifications.
- B. Concrete for thrust blocking shall be Portland cement concrete conforming to the applicable requirements of Section 02550 of these Specifications.

2.09 PIPE BEDDING AND BACKFILL MATERIAL

- A. Shall conform to Section 02202 of these Specifications.

PART 3 - EXECUTION

3.01 TRENCHING, BACKFILLING AND SHORING

- A. Shall conform to Section 02202 of these Specifications.

3.02 PIPE INSTALLATION

- A. Installation: Pipe, valves, fittings and appurtenances shall be installed in accordance with the best practice, and in conformance with the applicable requirements of the AWWA Standards. Each length of PVC pipe shall be rotated so that the stenciled or taped words "DOMESTIC WATER" will be located on the top of the pipe.
- B. Handling: Pipe, valves, and fittings shall be carefully handled during hauling, unloading, and placing operations, so as to avoid breakage or damage. Strap-type slings shall be used for lifting and placing; no chains or hooks will be permitted. Broken or damaged pipe or appurtenances will be rejected by the Engineer and shall thereupon be removed from the work and replaced.
- C. Alignment: All pipe shall be accurately laid in conformity with the prescribed lines and grades as established by the Engineer. Each length shall be jointed to the preceding section as specified, and after said jointing has been completed, there shall be no movement of the pipe in subsequent operations.
- D. Pipe Deflections: The laying of pipe on curved alignment will be permitted up to one-half the deflection as recommended by the respective pipe manufacturer.
- E. Cleaning: Before each new length of pipe is placed, the interior of the preceding pipe shall be carefully cleaned of all dirt and debris. When pipe laying is not in progress, all open pipe ends shall be closed with watertight plugs in a satisfactory manner.
- F. Bearing: Pipe in the trench shall have continuous uniform bearing along its bottom, except at bell holes. Blocking used to support the pipe during laying shall be placed at the end of the section and shall be removed before laying the next section. Before lowering pipe into the trench, the Contractor shall remove

all stakes, debris, loose rock and other hard material from the bottom of the trench.

- G. Positioning: After the final positioning, the pipe shall be held in place in the trench with backfill material placed equally on both sides of the pipe at as many locations as are required to hold the pipe section in place. After joints are completed, the backfill material shall be redistributed and compacted as herein required.
- H. Closure: At the end of each day and when work is not in progress, the open ends of pipe installed in the line shall be closed with watertight plugs or caps.
- I. Thrust: Blocking: Concrete thrust blocks of the form and dimensions shown or noted on the plans shall be provided at all changes in horizontal or vertical alignment and at such other points as may be called for on the plans. Thrust blocks shall be installed in strict conformance with the details shown or noted on the plans.

3.03 CONNECTIONS TO EXISTING SYSTEMS

- A. Connections to existing systems shall not be made until the new mains have been satisfactorily disinfected, sterilized and tested and have passed all tests herein specified.
- B. Connection of new water main to existing distribution system shall be performed no later than 48 hours after Bacteriological Examination Results have been received and approved by the Engineer. If the system connection is not performed within this period of time, Disinfection and Bacteriological Examination processes shall be repeated.

3.04 PRESSURE AND LEAKAGE TESTS

- A. Preparation:
 - 1. The Contractor shall provide all necessary material and equipment, and shall perform all work required in connection with the testing of the water system, as specified herein.
 - 2. Hydrostatic and leakage tests shall be made only after the trenches have been backfilled sufficiently to hold the pipe firmly in position.
 - 3. The Contractor shall provide all water necessary for filling, flushing, disinfection and any required tests including all labor and equipment required.
- B. Procedure:
 - 1. Any flaw disclosed by any of the above tests shall be repaired and satisfactorily re-tested.

2. The specified test pressure shall be satisfactorily applied by means of a pump connected to the pipe. The test pressure shall be maintained for the specified time and shall not be allowed to drop more than 5 psi during which all exposed pipe, couplings, fittings, valves and hydrants shall be examined carefully.
3. No PVC pipe installation will be accepted if the leakage for the section of line that is tested is more than that determined by the formula below:

$$L = \frac{ND\sqrt{P}}{7400}$$

Where:

- L = allowable leakage, gph
- N = number of joints in the length of pipeline tested
- D = nominal diameter of pipe, in.
- P = average test pressure during the leakage test, psig

4. When test results indicate leakage beyond that allowed, Contractor shall conduct a survey of the line, and any leaks found shall be repaired, after which the leakage test shall be repeated until satisfactory conformance to this specification is demonstrated.

3.05 DISINFECTION AND BACTERIOLOGICAL TEST

- A. Following the Pressure Test and before being placed in service, all new water lines shall be chlorinated in accordance with the requirements of AWWA Standard C651-99.

SECTION 02202

TRENCHING AND BACKFILL

PART 1 - GENERAL

1.01 WORK INCLUDED

- A. This section covers trenching and backfill requirements for buried piping systems specified in Water System - Section 02660; Storm Drainage - Section 02720; Sanitary Sewers -Section 02730; Irrigation Systems - Section 02910, Street and Safety Lighting -Section 16500.
- B. This Section also covers requirements for excavation and for compaction of succeeding layers after backfill has been placed around pipe.

1.02 APPLICABLE PUBLICATIONS

- A. The publications listed below form a part of this specification to the extent referenced. The publications are referred to in the text by the general designation only.
- B. American Society for Testing and Materials (ASTM) Publications:
 - C - 33 Specification for Concrete Aggregates
 - C - 136 Sieve Analysis of Fine and Coarse Aggregates
 - C - 150 Portland Cement
 - C - 260 Air Entraining Admixtures
 - D - 424 Plastic Limit and Plasticity Index of Soils
 - C - 618 Fly Ash and Raw or Calcined Natural Pozzolan for use as a Mineral Admixture in Portland Cement
 - D - 1557 Moisture-Density Relations of Soils and Soil Aggregate Mixtures Using 10-lb. (4.54 KG) Rammer and 18-in. (457 mm) Drop
 - D - 2419 Sand equivalent Value of Soils and Fine Aggregate
 - D - 2487 Classification of soils for Engineering purposes
 - D - 3017 Density of Soil and Soil Aggregate in Place by Nuclear Methods (Shallow Depth)

3. Use dust palliatives or reclaimed water (not potable water).
- F. Maintain access to adjacent areas at all times.
- G. Maintain and/or replace all bench marks, monuments, construction stakes and other reference points.
- H. Repair or restore damage to any portion of the work resulting from movement of the sides or bottom of trenches or other excavation which is attributable to the Contractor's acts or omissions, whether sides are braced or not.

PART 2 - PRODUCTS

2.01 GENERAL SOIL MATERIALS

- A. In general, soils used for backfill shall be select material free of debris, roots, wood, scrap material, vegetation, refuse, soft unsound particles, frozen, deleterious, or objectionable materials, satisfactory to the Engineer, free of stones or lumps exceeding 3 inches in greatest dimension.

2.02 PIPE BEDDING AND INITIAL BACKFILL MATERIAL

- A. Pipe bedding and initial backfill up to six inches above the top of the pipe shall be Class I, Type A permeable material, conforming to Section 68-1.025 of the Standard Specifications, except that the gradation for the #4 sieve shall be 30-55% passing, and gradation for the #8 sieve shall be 5 - 10% passing
- B. Material shall contain at least 75% of the particles having one or more fractured faces.
- C. Bedding and backfill material shall be subject to the approval of the Engineer.

2.03 SELECT BACKFILL ABOVE INITIAL BACKFILL OR BEDDING

- A. In non-paved areas unless otherwise shown on plans, select backfill shall conform to the requirements for soil materials above, and shall be classified as (GW), (GP), (GM), (SW), (SP) or (SM) by ASTM D 2487 and meet the following:
 1. Sand equivalent shall not be less than 25 when tested in accordance with ASTM D 2419, plasticity index shall not exceed 15 when tested in accordance with ASTM D 424, and not more than 25% by weight shall be finer than the No. 200 sieve.
 2. On-site native material may be used as backfill if it conforms to 2.03A.1. above.
- B. In paved areas, except Bay Mud, select backfill shall be Class 2 aggregate base, 3/4" maximum size gradation conforming to Section 25 of the Standard Specifications.

2.04 SPECIAL REQUIREMENTS FOR SELECT BACKFILL IN BAY MUD CONDITIONS

- A.** In areas where Bay Mud is prevalent, there are two distinct types of soil material present, Bay Mud and Imported Fill Material. Bay Mud consists of very soft, cohesive, clayey material, and it may be encountered from 1 to 4 feet below grade, depending on location. (At Redwood Shores for example, Bay Mud generally occurs at elevation 100). Excavated Bay Mud may be either segregated and hauled off the site, or dried and conditioned for placement back into the trench per Paragraph 3.07, at the Contractor's option.
- B.** The existing imported fill may be salvaged and used for backfill if it meets with the requirements of select backfill, per Paragraph 2.03.
- C.** Suitable excavated Bay Mud from trenches may be conditioned by aeration and used as backfill. To accelerate drying to optimum moisture content for compaction as backfill, spreading, disking or harrowing may be required.

2.05 SUBDRAIN MATERIAL

- A.** Where required for trench drainage and for subsurface drains, bedding shall conform to the requirements of Class 1, Type A Permeable material per Section 68 of State Standard Specifications.

2.06 CONTROLLED DENSITY FILL (CDF) (in trenches)

- A.** Controlled density fill will be accepted in lieu of the standard backfill specifications. It shall be mandatory in trenches eight (8) inches wide or less where the prevention of subsequent settlement after placement of backfill is required. CDF shall conform to the following requirements:
 - 1. Strength Requirements
 - a. Non-structural CDF that can be excavated by hand shall produce unconfined compressive 28 day strengths from 50 psi to a maximum of 150 psi. CDF that is to be excavated by hand shall contain aggregate no larger than 3/8" top size nor shall the 3/8" aggregate comprise more than 30% of the total aggregate content.
 - 2. Materials
 - a. Cement shall meet the standards as set forth in ASTM C-150, Type II Cement.
 - b. Fly ash shall meet the standards as set forth in ASTM C-618, for Class F pozzolans. The fly ash shall not inhibit the entrainment of air.
 - c. Air entraining agent shall meet the standards as set forth in ASTM C-260.
 - d. Aggregates need not meet the standards as set forth in ASTM C-33. Any aggregate, producing performances characteristics of the CDF, for any project will be accepted for consideration as follows. The amount of

material passing a #200 sieve shall not exceed 12% and no plastic fines shall be present.

3. Mix Proportions

- a. CDF shall be a mixture of cement, Class F pozzolan, aggregate, air entraining agent and water. CDF shall be batched by a ready mixed concrete plant and delivered to the job site by means of transit mixing trucks except for
- b. The actual mix proportions shall be determined by the producer of the controlled density fill to meet job site conditions, minimum and maximum strengths, and unit weight. Entrained air content shall be a minimum of 4.0%. The actual entrained air content shall be established for each job with the materials and aggregates to be used to meet the placing and unit weight requirements. Entrained air content may be as high as 20% for fluidity requirements.

4. Mix Design

- a. Mix design shall meet the Engineer's approval.

PART 3 - EXECUTION

3.01 GENERAL TRENCHING AND EXCAVATING

- A. Trenches may be excavated either by hand, or by machine. Trenches shall be cut with vertical sides, and shall be of sufficient width to provide adequate space for working therein; such space shall be a minimum clear distance of six (6) inches of shoring and a maximum of nine (9) inches clear of shoring on each side of the pipe barrel when the pipe is properly placed and aligned in conformity with the plans. Glory hole excavation or vee trenches will not be allowed. Trench sides shall be parallel to and at equal distance from the center-line of the pipe, when aligned in conformity with the plans.
- B. Excavated material shall be loaded into trucks immediately upon removal from the trench to prevent stockpiling on roadways or walkways.
- C. Where the excavated trench exceeds the widths specified above, furnish higher strength pipe, or other methods of construction as approved by the Engineer, to adequately provide for the increased loading, which the trench widening will cause. Stepped trenches shall meet the approval of the Engineer.
- D. Pipe trenches shall be excavated to a depth below the bottom of the pipe sufficient to provide for pipe bedding materials as required by Section 3.02.
- E. Where a trench has been excavated below the designed grade, the bottom of the trench shall be refilled to proper subgrade with approved material well compacted in place, in an approved manner.

- F. The Engineer shall have the right to limit the amount of trench which is opened or partially opened at any one time; and also to limit the amount of trench left without backfill, at any one time.
- G. No trench or holes shall be left open overnight. Use steel pating to protect open trenches overnight.
- H. Excavation for thrust blocks shall be neat to the line and dimensions shown or called for on the plans.
- I. Provide for dewatering trenches and excavations and subsequent control of ground water, utilizing such pumps or other equipment as may be necessary to control ground water and seepage until backfilling is completed.

3.02 GENERAL BEDDING

- A. Utilities shall be laid on a firm layer of firm bedding material not less than four (4) inches in depth as shown or as noted on the plans and detail drawings, except that bedding shall not be required for utilities two (2) inches or less in nominal diameter. Compact as specified herein.
- B. Upon completion of bedding operations and, prior to the installation of pipe or appurtenances, notify the Engineer who will then inspect the bedding layer. Pipe laying shall not commence until the bedding has been approved.

3.03 GENERAL BACKFILLING

- A. Backfill shall be as shown on the plans. Place in 6-inch maximum loose lifts to one foot above pipe unless otherwise specified. Bring up evenly on each side, and for the full length of the structure. Ensure that no damage is done to structures or protective coatings thereon. Place the remainder of the backfill in 8-inch maximum loose lifts unless otherwise specified. Compact each loose lift as specified in Paragraph "General Compaction" before placing the next lift. Where unacceptable settlements occur in trenches and pits due to improper compaction, excavate to the depth necessary to rectify the problem, then backfill and compact the excavation as specified herein and restore the surface to the required elevation.
- B. No backfill shall be placed until the line has been inspected and approved for backfilling.

3.04 GENERAL COMPACTION

- A. Use hand-operated plate type vibratory or other suitable hand tampers in areas not accessible to larger rollers or compactors. Be careful to avoid damaging pipes and protective pipe coatings. Compaction shall be in accordance with the following unless otherwise specified. If necessary, the Contractor's selected equipment and construction procedure shall be altered, changed or modified in order to meet the specified compaction requirements.

- B. Initial backfill and bedding shall be carefully packed under the haunches of the pipe and brought up simultaneously on both sides so as to obviate any displacement of the pipe from its true alignment. Bedding shall be compacted in layers not more than eight (8) inches in thickness in a manner that will preclude moving the pipe, to not less than 95% of maximum dry density as determined by the procedure set forth in ASTM Designation D1557. Jetting of backfill material will not be permitted.
- C. Select backfill above the initial backfill shall be placed in loose lifts not exceeding eight (8) inches in thickness before compaction, and compacted by the use of pneumatic tampers or other mechanical means approved. Water or dry, as required, to bring the soils as close as practicable to the optimum moisture content for proper compaction. Compaction equipment or methods that produce horizontal or vertical earth pressures which may cause excessive displacement or may damage the pipeline will not be permitted. Lifts of backfill shall be compacted to not less than 95% of maximum dry density as determined by the procedure set forth in ASTM Designation D1557. Jetting of backfill material will not be permitted.
- D. For flowable CDF, compaction is not necessary for placement. Trench sections may be filled in one lift above the initial backfill material.
- E. Backfill will be inspected and tested by the Engineer during placement. Contractor shall cooperate with the Engineer and shall provide working space for such tests in his operations. Backfill not compacted in accordance with these specifications shall be recompacted, or removed as necessary and replaced to meet specified requirements prior to proceeding with the work.

3.05 GENERAL BRACING AND SHORING

- A. The Contractor shall furnish, place and maintain such bracing and shoring as may be required to support the sides of the excavations for the proper protection of workmen; to facilitate the work; and to prevent damage to adjacent structures or facilities.
- B. Upon completion of the work, all bracing and shoring shall be removed, unless otherwise directed by the Engineer. Current requirements are for a maximum depth of 5 feet without CAL-OSHA approved shoring.

3.06 SPECIAL REQUIREMENTS FOR SHORING AND EXCAVATING IN BAY MUD

- A. Trenches or other excavations, where the distance from the existing grade to the bottom of the excavation exceeds eight (8) feet, shall be interlocking, continuous solid sheathing. Said sheathing shall be designed to resist an equivalent fluid pressure having a density of at least 100-lbs. per cubic foot for the full height of the trench and shall be installed for the full depth of trench and to a sufficient depth below the bottom of the excavation to prevent heaving of the bottom, and shall be adequately supported in place with walers and braces. Fill voids between sheathing and trench wall with pea gravel.

- B. Mandatory use of solid sheathing at designated locations shall not relieve the Contractor of the responsibility to install sheathing at other locations required or where necessary for safety of workmen or the general public. Excavations below Bay Mud shall be accomplished between previously placed sheathing and bracing in those areas where solid sheathing is required. The required bracing and sheathing will be installed prior to excavating below braced elevation.
- C. Material which is salvaged from the trench and stockpiled for later use as backfill, shall be stored a minimum distance of 10 feet, but no less than 3 times the trench depth from the edge of the excavation.
- D. Sheathing shall be withdrawn only after backfill above the pipe has proceeded to a height equal to or greater than 3/4 of the excavation depth. Bottom cross bracing and walers may be left in place upon removal of the sheathing. Backfill shall be brought to the level of the cross-braces before these are removed.
- E. Install and extract the sheathing in a manner which will not disturb the line, grade, backfill compaction or operation of the utility being installed or adjacent utilities and improvements.

3.07 SPECIAL REQUIREMENT FOR BACKFILL IN BAY MUD CONDITIONS

- A. Bay Mud, if used as backfill at the Contractor's option, shall be spread and dried to optimum moisture content, then replaced in the trench to the same elevation below grade as the existing Bay Mud, as directed.
- B. Imported fill material, which has been salvaged from trench excavation for use as select backfill, shall be stockpiled alongside the excavation unless otherwise directed. Material shall not be stockpiled higher than four (4) feet and shall be kept back from the trench a horizontal distance at least equal to the depth of excavation.
- C. All material excavated within the limits of work, not required as backfill, shall then be transported and dumped or conditioned to optimum moisture content and compacted as embankment at the site noted on the plans or as directed.
- D. On-site native Bay Mud for use as backfill shall be conditioned by means of watering or aeration as may be required to bring the material to the range of moisture content satisfactory for compaction to project specification.
- E. Prior to placing conditioned material as backfill, the material shall be thoroughly and uniformly mixed to the satisfaction of the Engineer, and the moisture content shall be within the allowable range for compaction to project specification. Material which has dried to less than allowable moisture content shall be reconditioned to an acceptable moisture content and re-mixed to the satisfaction of the Engineer.

3.08 SPECIAL REQUIREMENT FOR COMPACTION IN BAY MUD

- A. Compaction procedures are as described in paragraph "General Compaction" except that the density of compaction shall be 90% as determined by ASTM

Designation D1557, except for the top 6" in paved areas which shall be compacted to 95%.

- B. Remove shoring or sheathing as described above, making sure that the pipe is not displaced.

3.09 SPECIAL EARTHWORK REQUIREMENTS FOR SUBSURFACE DRAINS

- A. Excavate to the dimensions indicated.
- B. Provide a bedding surface of uniform density consisting of permeable material as indicated.
- C. Backfill around and over the pipes after pipe installation has been approved with permeable material to the depth indicated. Place in maximum loose lifts of 8 inches.
- D. Compact each lift with mechanical tampers or rammers. Compact bedding and backfill materials to 90% of ASTM D1557, Method D, maximum density. Place the remainder of the trench backfill as specified.

3.10 SPECIAL REQUIREMENTS FOR CONTROLLED DENSITY FILL (CDF)

- A. Applications of CDF include, but are not limited to: backfills, structural fills, insulating fills, road base, slab base, trench bedding, void and abandoned tank fills caisson and pile fills, abandoned pipes and culverts.
- B. CDF shall be discharged from the mixer by any reasonable means into the area to be filled. CDF shall be brought uniformly to the elevation as shown on the plans. Trench sections to be filled with CDF shall be contained at either end by bulkheads of earth fill.
- C. Permanent pavement may be placed directly upon the CDF as soon as it has sufficiently self-consolidated so that the surface will withstand the process of paving without displacement or disruption. If the placement of the CDF is not completed early enough to allow for permanent paving to be completed the same day, the contractor shall provide steel plates to span the trench and prevent traffic contact with the CDF overnight or until permanent paving can be placed.
- D. Compaction is not necessary when placing CDF.

3.11 FIELD QUALITY CONTROL

- A. The Engineer will inspect, test and approve trench backfill layers before further construction is permitted thereon. Number of tests required will be determined by the Engineer.
- B. If backfill has been placed, that is below the specified density, provide additional compaction with subsequent retesting until successful compaction is achieved.

3.12 DUST ALLEVIATION AND CONTROL

- A.** Contractor shall be responsible for and shall provide pollution and dust abatement and control measures satisfactorily during the course of the work.
- B.** The Contractor shall utilize reclaimed water, or dust palliatives, in compliance with the City's Water Conservation Ordinance.

3.13 FINISH OPERATIONS

- A.** Pipes shall be laid to finished grades indicated on the plans.
- B.** Dispose of all surplus material or material unsuitable for filling or grading off the site in a legal manner.
- C.** Satisfactorily restore any existing improvements, paving, landscaping, and other utilities disturbed during the course of constructing the improvements.
- D.** Existing traffic markings and control devices damaged or disturbed during construction shall be replaced or repaired to the satisfaction of the Engineer.

* * *